

Zbigniew WILK, Jacek MOTYKA, Irena JÓZEFKO

INVESTIGATIONS OF SOME HYDRAULIC
PROPERTIES OF KARST SOLUTION OPENINGS
AND FRACTURES

(12 Figs.)

*Badania niektórych cech hydraulicznych
pustek krasowych i szczelin*

(12 fig.)

Zbigniew Wilk, Jacek Motyka, Irena Józefko: Investigations of some hydraulic properties of karst solution openings and fractures. *Ann. Soc. Geol. Poloniae*, 54-1/2: 15-43 Kraków.

Abstract: The results of a detailed survey of fractures and karst forms to be observed in underground mines in the Cracow-Silesia zinc and lead ore district are presented. A classification of karst solution openings, based on the ratios of the lengths of half-axes of the ellipses to which the cross-sections of the openings were compared, is proposed. Making simplified assumptions a formula has been derived which enables to estimate the filtration coefficient of a rock massif using the results of direct measurements of the geometrical parameters of fractures. Using the Colebrook-White's formula the values of the coefficient of hydraulic friction of the karst passages under investigation have been estimated.

Key words: karst forms, fractures, hydraulic resistance, filtration coefficient, carbonate rocks, Triassic, Cracow-Silesia ore district.

Zbigniew Wilk, Jacek Motyka: Instytut Hydrogeologii i Geologii Inżynierskiej, Akademia Górniczo-Hutnicza im. St. Staszica, al. Mickiewicza 30, 31-009 Kraków (Poland).

Irena Józefko: Przedsiębiorstwo Geologiczne w Krakowie, al. Kijowska 14, 30-079 Kraków (Poland).

manuscript received: August, 1982

accepted: March, 1983

Treść: Przedstawiono wyniki szczegółowego zdjęcia przekrojów form krasowych napotkanych w podziemnych wyrobiskach kopalń rud cynku i ołowiu Olkusz i Pomorzany. Sklasyfikowano te formy na podstawie kryterium stosunku długości osi półelips, do których przyrównano przekroje tych form. Przyjmując uproszczone założenia wyprowadzono wzór na przybliżoną wartość współczynnika filtracji masywu skał spękanych, który uwzględnia szerokości pojedynczych szczelin, uzyskane na podstawie bezpośrednich pomiarów. Stosując wzór Colebrook-White'a obliczono wartości bezwymiarowych współczynników oporów hydraulicznych obserwowanych kanałów krasowych.

INTRODUCTION

During the past several years there has been an increasing interest in the hydrology of carbonate terrains, karst features and hydraulic properties of karst-fissured rocks. This brought among others many international meetings of specialists (e.g. Colloque de Dubrovnik, 1965, Actes de colloque, 1967: AIH Twelfth International Congress in Huntington, Alabama, 1976, Proceedings 1977), and monographs (Burger, Dubertret ed., 1975, Zötl, 1974: Bögli, 1978: Jakucs, 1977). For further examples see: La Moreaux, Le Grand, Stringfield (1975). An increasing interest in karst hydrogeology can be also observed in Poland. It has resulted in most cases from practical needs, in connection with difficult groundwater problems which have to be solved as for instance on the occasion of developing new big mineral deposits like the copper ore deposit in the Fore-Sudetic Monocline, coal deposits in the Lublin Coal Basin, the Bełchatów lignite deposit and the zinc-lead ore deposit in the vicinity of Olkusz.

The karst-fissured aquifer within which the last mentioned ores occur has been the subject of the authors' investigations since a decade.

In the previous papers by the authors the general geological setting and some principal as well as particular groundwater problems of the region under consideration were discussed (Wilk, Motyka, Niewdana, 1971, 1973; Wilk, Zimny, 1973; Wilk, Motyka, 1977; Wilk et al., 1977; Adamczyk, Wilk, 1978; Haładus et al., 1978). The authors have also characterized, on the basis of pumping tests and observations in prospecting bore-holes, the hydraulic properties of the ore-bearing Triassic rock massif as a whole (Motyka, Wilk, 1976; Wilk, Motyka, 1980).

Since in the world literature there is little to be found regarding the estimation of hydraulic parameters of karst solution openings and fractures, the authors have made an attempt of such a study. As the object of our observations and calculations we took the discussed rock massif. In this paper the first results of this study are presented.

List of symbols used in the paper:

- b_i – width (thickness, aperture) of a single fracture (m);
- b_m – equivalent width of a group of fractures (m);
- B_i – correction factor for the roughness of discontinuities surfaces equal to:
 - after Łomize (1951) $B_i = 1 + 6.0 (e_i/b_i)^{1.5}$
 - after Wittke, Louis (1968) $B_i = 1 + 8.8 (e_i/2b_i)^{1.5}$
- d_z – equivalent diameter of a karst channel cross-section (m);
- e_i = absolute roughness for fracture surfaces (m);
- F – cross-section area of the examined portion of a jointed rock massif (m²);
- F_k – cross-section area of a karst channel (m²);
- g – gravity acceleration (m · s⁻²);
- J – hydraulic gradient;
- k – coefficient of filtration of a porous medium equivalent to that of a portion of a fractured massif (m · s⁻¹);

- l_i – length (persistence) of a single fracture (m);
 n_F – coefficient of fracture-porosity;
 Q_m – discharge of flow through the cross-section of a fractured massif ($m^3 \cdot s^{-1}$);
 Q_p – discharge of flow through the cross-section of a porous medium ($m^3 \cdot s^{-1}$);
 Re – Reynolds number, $Re = \frac{v \cdot d}{\nu}$;
 Re_{kr} – critical value of Reynolds number;
 v – water flow velocity in a karst channel ($m \cdot s^{-1}$);
 w – absolute roughness of karst channel walls (m);
 x – length of the horizontal half-axis of the ellipse equivalent with respect to the size to a cross-section of a karst channel (m);
 y – length of the vertical half-axis of the ellipse equivalent with respect to the size to a cross-section of a karst channel (m);
 Γ_F – areal frequency (density, specific length) of fractures (m^{-1});
 λ – coefficient of hydraulic friction;
 ν – kinematic viscosity of the fluid ($m^2 \cdot s^{-1}$). For water at a temperature of $10^\circ C$ $\nu = 1.31 \cdot 10^{-6} m^2 \cdot s^{-1}$.

METHOD OF INVESTIGATIONS

The measurements of geometrical elements of fissures, fractures and joints in the carbonate sediments of the Lower Muschelkalk were carried out in the mine workings of the Olkusz Mine (12 measurement sites) and in the Pomorzany Mine (5 measurement sites). At all the measurement sites maps of the fracture patterns were made and the thickness and length of each fissure measured. In the Pomorzany Mine the measurements of the directions of the fissures were also carried out. On account of the special conditions of observations and measurements in underground mine workings when selecting the measurement sites we took into consideration in the first place their accessibility and the kind of the gallery lining as well as the intensity of exploitation and transport.

When discussing the methods of measuring the width of the fissures we cannot neglect the problem of changes in the value of this parameter resulting from the lateral unloading of the rock massif. The problem of the effects of lateral pressure release around the mine workings is a separate point in the literature dealing with rock mechanics. Generally speaking, we can say that the relaxation of rocks is responsible for an increase of the width of the fissures which can be observed on the gallery side wall. The increase in the width depends on the state of primary stress in the rock mass, the mechanical properties of rocks, depth and shape of the mine working, geometry of the fractures and others. This problem, however, is a complex one and not easy to investigate.

Since in the investigated rock massif situated at little depth (100 to 200 m) there occur numerous karst solution openings and tectonic fissures which made possible an earlier relaxation of the rock mass, we may assume a hypothesis,

based on intuition, that the effect of rock mass relaxation following the excavation work is small and can be neglected.

The width of the fissures was measured by means of a feeler gauge with an accuracy up to 0.05 mm. Their directions were measured by means of a geological compass.

According to Liszkowski and Stochlak (1976) the proportion of fissures on the examined surface areas of a mine gallery face or side wall was characterized by means of the coefficient of areal fracture-porosity calculated from the formula

$$n_F = \frac{\sum_{i=1}^n l_i \cdot b_i}{F} \quad (1)$$

and the frequency of fractures on the examined surface area by means of the coefficient calculated from the formula

$$\Gamma_F = \frac{\sum_{i=1}^n l_i}{F} \quad (2)$$

The explanation of symbols is given in the introduction.

The measurement results of the width and length of the fractures were used to calculate their equivalent width (b_m) in the examined portion of a cross-section of the rock massif. The authors assumed equal flow rate through the examined portion of the cross-section of a real rock massif and through a portion of identical size of a cross-section of a fictitious one cut by fractures of identical width (b_m) and of the total length equal to the total length of fractures measured on the examined portion of the cross-section of a real rock massif.

They also applied Boussinesq's explicit equation together with a simplifying assumption of equal hydraulic gradient in all fissures and the assumption that flow velocity vector is parallel with the walls of fractures.

Applying the symbols as given in the notation (see Introduction), the assumption of equal flow intensity through the crosssections of identical size of a fictitious and a real massif can be expressed as follows:

$$\frac{J \cdot g}{12\nu} \sum b_i^3 l_i = \frac{J \cdot g}{12\nu} b_m^3 \sum l_i \quad (3)$$

From Eq. (3) we obtain the formula for the equivalent width of fractures:

$$b_m = \sqrt[3]{\frac{\sum b_i^3 \cdot l_i}{\sum l_i}} \quad (4)$$

What regards the karst forms the investigations included nearly exclusively open karst passages and solution openings, i.e. cavities as defined by Choquette and Pray (1970) or Radomski and Unrug (1977). The shapes of the cross-sections of the particular cavities formed as a result of the intersection of the given

karst form and the side wall of a mine working were determined and the directions of the karst passages measured. Altogether there were carried out observations of the shape of the cross-sections of 62 cavities out of which 25 in the Olkusz Mine and 37 in the Pomorzany Mine. The directions of 194 passages were measured out of which 157 in the Olkusz and 37 in the Pomorzany Mines.

The shape of a cross-section of a karst passage formed as a result of its intersection with a wall of a gallery depends on the angle formed by the gallery wall plane and the plane created by the main axes of the karst form cut by the gallery (Fig. 1).

Depending on the interrelation between these spatial elements the width or height of the cross-section of the examined karst form may become deformed in various degree. From previous investigations of many researchers it is known, however, that karst passages are characterized by great variety of dimension and direction. For that reason, in the authors' opinion, the formation of the observed shape of the cross-section of a karst form on the wall of a mine working has a random character, and thus it is suitable for statistical elaboration. In the examined material we neglected, however, the isolated cases of karst forms, intersected by mine workings which are parallel to their longitudinal axis (Fig. 1a, b, d).

An error in the correct determination of the shape of a cross-section of some karst channels results also from the fact that in some cases the side wall of a gallery cuts it only tangentially (Fig. 1e).

After the contour of a cross-section of a cave intersected by the side wall of a gallery was drawn in appropriate scale the surface area of that cross-section was determined by planimetry method. To determine the regularity of the examined cross-sections each of them was transformed into an ellipse equivalent with regard to the size of the surface area. As a measure of regularity the ratio of the horizontal half-axis of the ellipse (x) and its vertical half-axis (y) was assumed. The length of one half-axis, which was most frequently the longer one, was measured directly in the mine working, the other one was calculated from the formula:

$$y = \frac{F_k}{\pi x} \quad (5)$$

As "horizontal" or "vertical" have been considered such ellipse half-axes which create an angle $\alpha < 50^\circ$ with the respective axes of the rectangular coordinate system. The difficulties in measuring the direction of the karst passages were great in case of extended karst forms developed along the bedding planes. Karst passages of this type, however, constituted only a small proportion of the whole population under investigation. Some of the examined caves had visible branchings (Fig. 1f). In such cases the directions of longitudinal axes were measured in all the branches of the examined karst passage.

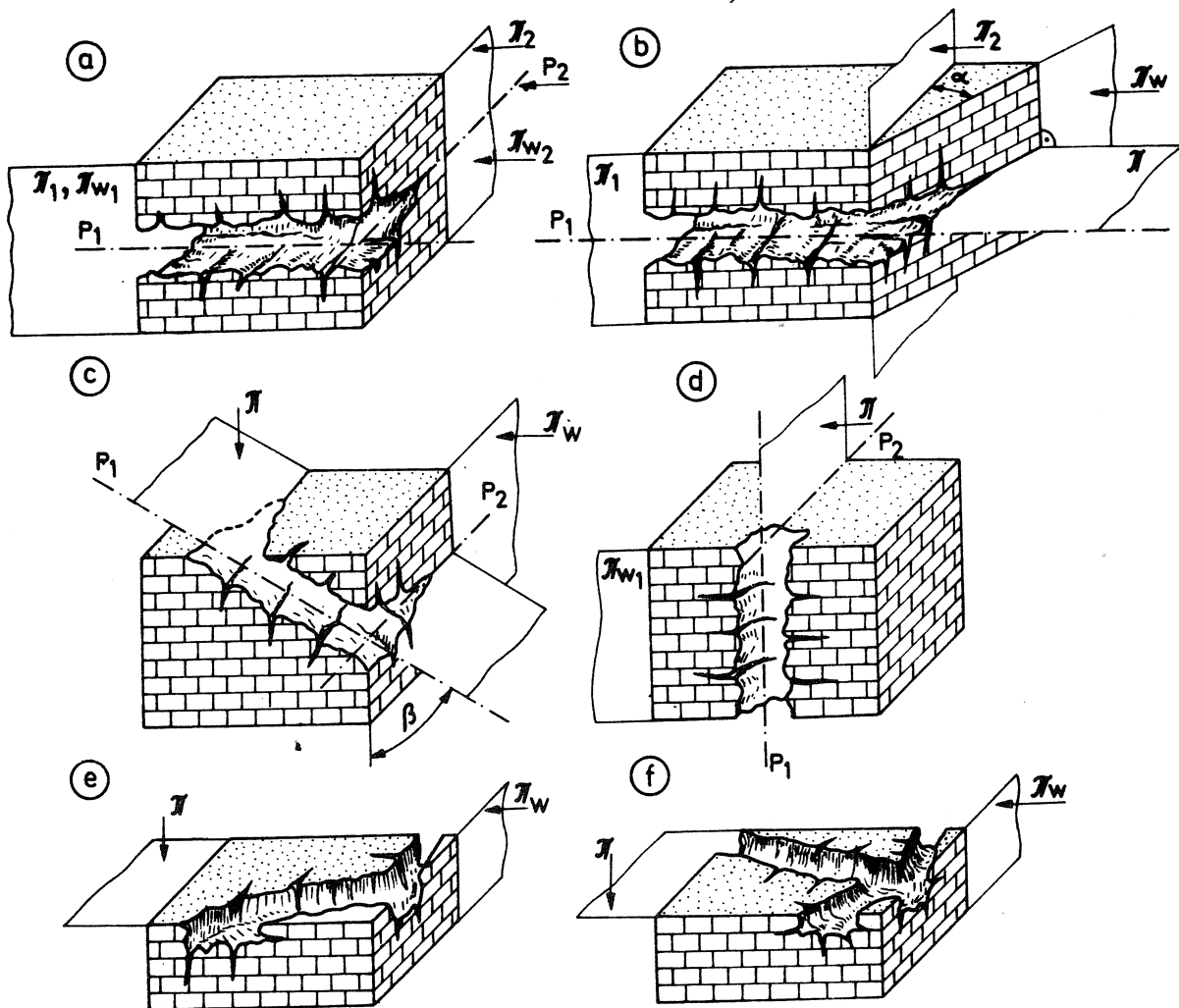

Fig. 1. Examples illustrating the possibility of deformation of the representation of actual shapes of the cross-sections of karst channels as a result of their intersection with the geometrical elements of underground mine workings (e.g. head, side wall, bottom, roof). P_1 – axis of the karst channel, P_2 – longitudinal axis of the cross-section of a karst channel lying in the plane π_2 , π – plane determined by the axes P_1 and P_2 ; π_1 – vertical plane passing through the axis P_1 , π_2 – vertical plane normal to the axis P_1 and passing through the axis P_2 , π_w , π_{w1} , π_{w2} – planes passing through arbitrary geometrical elements of the mine working; $a-d$ – cross-sections of karst channels (horizontal and vertical) which do not result in a deformation of the representation of their actual shapes and dimensions due to intersection, b – planes π and π_w intersecting at an angle α which causes apparent increase of horizontal dimensions of the cross-section of the channel; c – planes π and π_w intersecting at angle β , which causes apparent increase of vertical dimensions of the cross-section of the channel, e – a winding karst channel cut with a mine working which does not provide information about its actual shape and direction, f – karst channel cut with a mine working not informing about the existence of its branchings

Fig. 1. Przykłady ilustrujące możliwość deformacji obrazu rzeczywistych kształtów przekrojów kanałów krasowych w wyniku ich intersekcji z geometrycznymi elementami podziemnych wyrobisk górniczych (czoło, ocios, spąg, strop), P_1 – oś kanału krasowego, P_2 – oś podłużna przekroju kanału krasowego leżącego w płaszczyźnie π_2 , π – płaszczyzna wyznaczona przez osie P_1 i P_2 ; π_1 – płaszczyzna pionowa przechodząca przez oś P_1 , π_2 – płaszczyzna pionowa prostopadła do osi P_1 , π_2 – płaszczyzna pionowa prostopadła do osi P_1 i przechodząca przez oś P_2 , π_w , π_{w1} , π_{w2} – płaszczyzny przechodzące przez dowolne elementy geometryczne wyrobiska, $a-d$ – przekroje kanałów krasowych (poziomego i pionowego) nie powodujące zniekształcenia obrazu ich rzeczywistych kształtów i wymiarów w wyniku intersekcji, b – płaszczyzny π i π_w przecinają się pod kątem α , co powoduje pozorne powiększenie poziomych wymiarów przekroju poprzecznego kanału, c – płaszczyzny π i π_w przecinają się pod kątem β , co powoduje pozorne powiększenie pionowych wymiarów przekroju poprzecznego kanału; e – nacięcie wyrobiskiem krętego kanału krasowego nie informujące o jego rzeczywistym kształcie i kierunku, f – nacięcie wyrobiskiem kanału krasowego nie informujące o istnieniu jego rozgałęzień

RESULTS OF EXAMINATION

The main features of fissures on which the hydraulic properties of a jointed massif depend are the width, spacing and orientation in space. The width of the fractures is responsible for the hydraulic conductivity of the massif, and their spacing considerably affects its groundwater storativity. Spatial orientation of fissures determines the local directions of water flow in the fractured rockmass.

On the basis of macroscopic observations of the side walls in mine drifts and cross-cuts it has been found that the examined massif is fractured to a very large degree. Sporadically only in the mine workings we can find zones of solid rock, which are scarcely fractured.

The measurements of the width of the void space in each fracture and the length of fissures in the Olkusz Mine have been carried out at 12 measurement sites, localized in a water gallery excavated in the limestone of the Gogolin Beds at a depth of about 100 m from the ground surface. The measurement results of the width of fissures are shown in the form of a synthetic histogram of the relative frequency distribution of this feature (Fig. 2).

In the Pomorzany Mine the observations and measurements of the fissures were carried out in the workings excavated in the ore-bearing dolomite (3 measurement sites) and in the limestone of the Gogolin Beds (2 measurement sites)

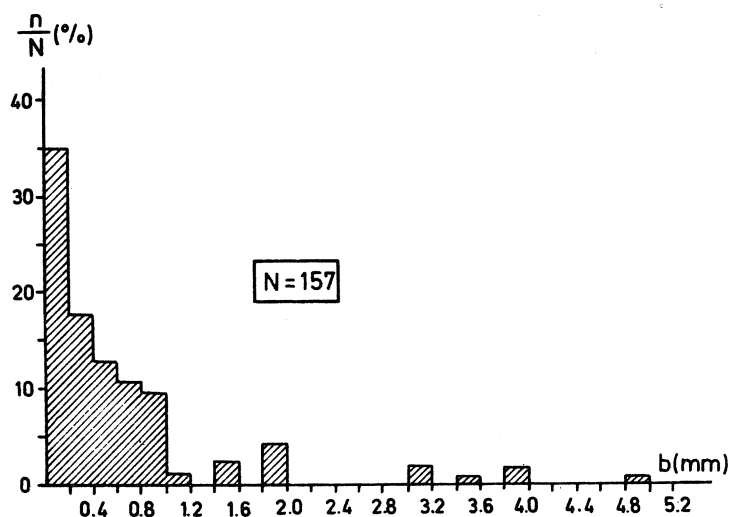

Fig. 2. Distribution of the width of joints in the limestone of the Gogolin Beds in the western part of the Olkusz Mine. N – total number of joints, n – number of joints in the given width class.

Fig. 2. Rozkład szerokości spękań w wapieniach warstw gogolińskich w zachodniej części kopalni Olkusz. N – ogólna liczba spękań, n – liczba spękań w danej klasie szerokości

at a depth of about 150 m from the ground surface. The relative frequency distributions of the fissure width at the particular measurement sites are shown in Fig. 3.

From the histogram of the distribution of the fissure width (Fig. 2) in the limestone of the Gogolin Beds in the western part of the Olkusz Mine it can be seen that a decided majority of fractures is characterized by a width less than 1.0 mm, with a modal value of about 0.2 mm, and the maximum value ca 5 mm. In the measurement sites in the Pomorzany Mine fractures of a width less than 0.4 mm were the prevailing ones, the most frequent ones being equal to 0.2 mm (Fig. 3). The maximum width of fractures in the measurement sites 1, 4, 5 was

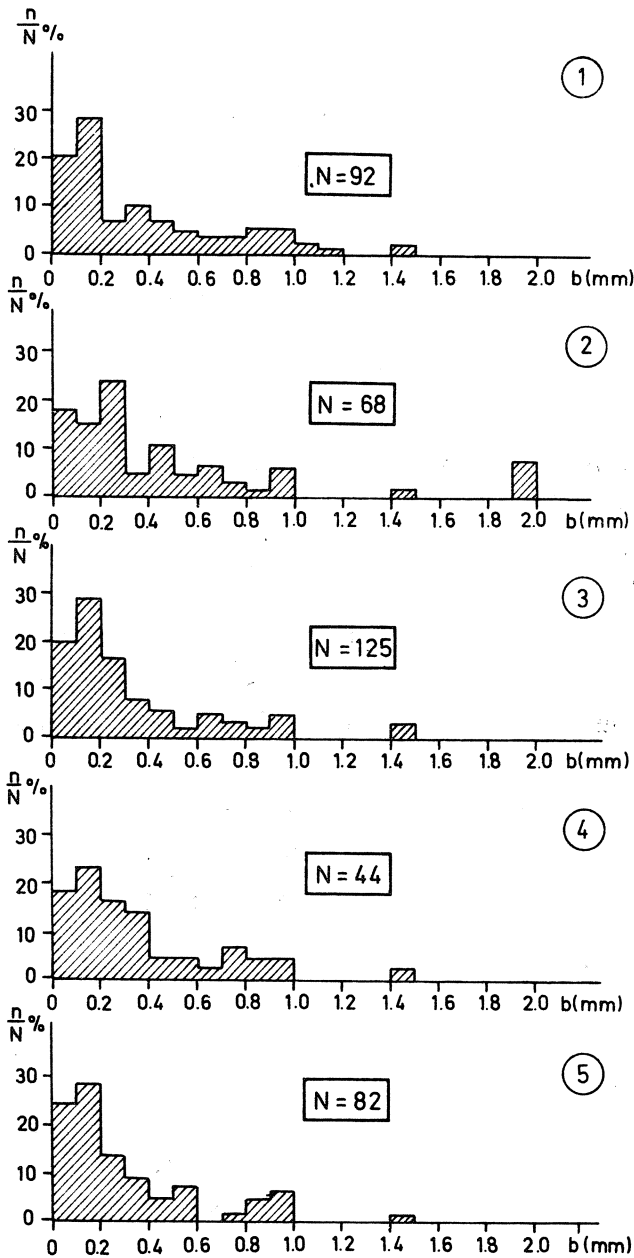

Fig. 3. Distribution of the width of joints in the particular measurement sites in the Pomorzany mine. N, n – as in Fig. 2

Fig. 3. Rozkład szerokości spękań w poszczególnych punktach pomiarowych w kopalni Pomorzany. N, n – jak na fig. 2

ca 1.5 mm, in the measurement site 2 the maximum width was up to 2.0 mm, and about 2.5 mm in site 3. It is also worth to notice that the distributions of the width in all the portions of the examined massif are asymmetric with positive skewness.

A comparison of the distribution of the fracture width in the Olkusz and the Pomorzany Mines proves that while the modal values in both mines were similar a proportion of fractures of greater width was distinctly greater in the Olkusz Mine. However in both mines we can find small massif fragments in which fractures occur the width of which was several centimeters.

The absence of fractures of greater width in the galleries of the

Pomorzany Mine which is deeper than the Olkusz Mine, is connected with the general rule of decreasing of the fracture width with increasing depth (Király, 1975) what corresponds with the increase of the petrostatic pressure and the decrease of the groundwater circulation intensity.

For each measurement site there were calculated the fracture porosity according to formula (1), the fracture-frequency (density) according to formula (2) and the equivalent width of fractures according to formula (4). Examples of fragments of the examined massif with various spacing of fractures are shown in Fig. 4, and the calculation results of the above mentioned indices are listed in Table 1. A comparison of the distribution of the width of joints, the index values of the fissure-porosity and of the spacing of joints proves that the examined fragment of the limestone of the Gogolin Beds in the western part of the Olkusz Mine is characterized by a greater width of fissures than the rocks observed in the Pomorzany Mine; it shows, however, a considerably smaller values of the indices of fissure-porosity and of fissure spacing.

The fissures are important ways of groundwater circulation, and their spatial orientation determines the local flow direction of these waters.

The results of measurements of the direction of joints carried out at the particular measurement sites of the Pomorzany Mine are presented in Fig. 5.

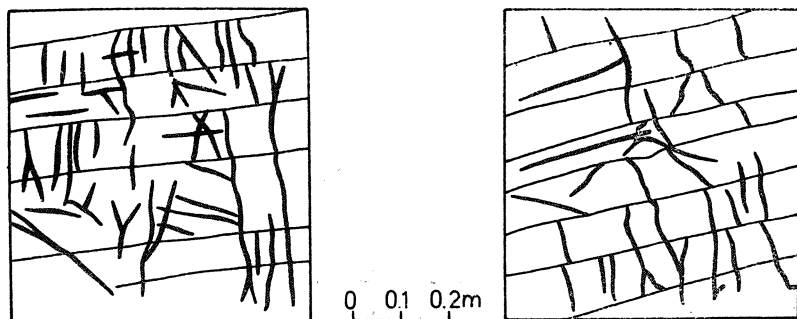
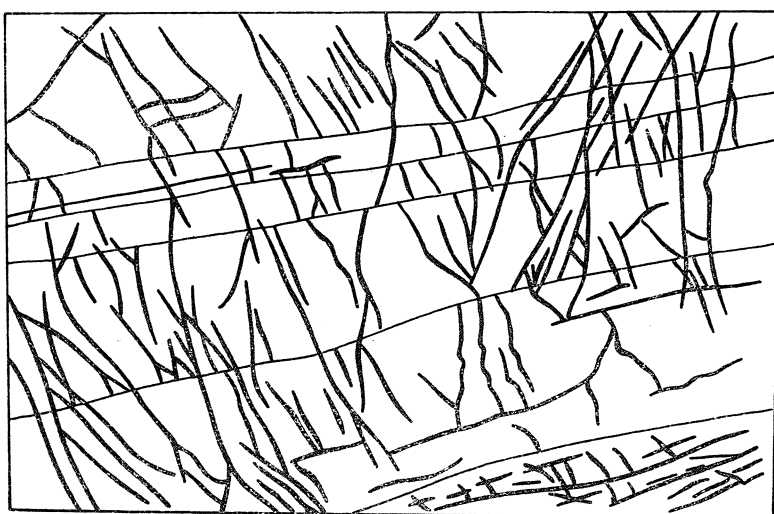
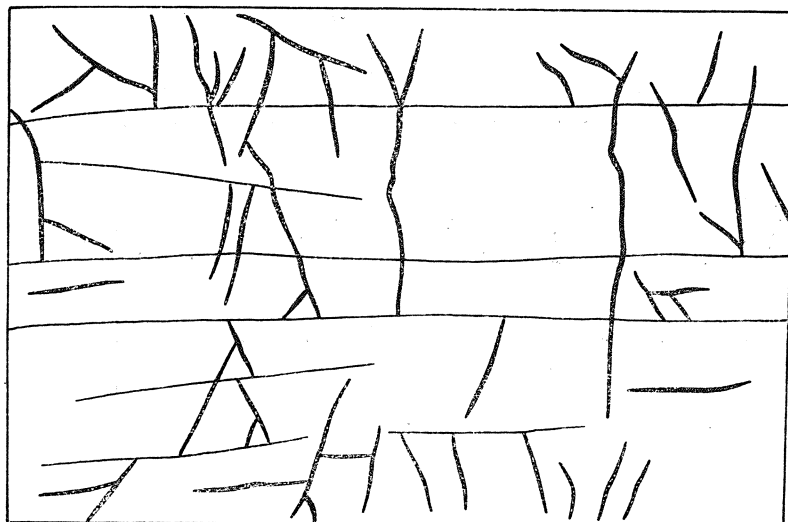

Fig. 4. Examples of fissure patterns in the Muschelkalk visible on the side walls of mine workings in the Pomorzany Mine

Fig. 4. Przykłady planów spękań utworów wapienia muszlowego widocznych na ociosach wyrobisk w kopalni Pomorzany



Independently of distinct, individual differences in the distribution of the directions of fissures in the particular measurement sites, generally speaking, we may distinguish two systems of joints with the directions $20-60^\circ$ and $320-360^\circ$. On the whole we can say that the measurement results of the directions of fissures

Table - Tabela 1
 Hydrogeological characteristics of fractures in the carbonate Triassic rocks
 Cechy hydrogeologiczne szczelin w węglanowych skałach triasowych

Mine Nazwa kopalni	Measurement site No. Nr stanowiska pomiarowego	Lithostratigraphic unit Jednostka litostratygraficzna	Size of the examined surface area F (m ²)	Coefficient of fracture- porosity n_F (%)	Areal frequency of fractures Γ (m ⁻¹)	Equivalent width of fractures b_m (mm)	Coefficient of filtration (calculated) k (m/s)
Olkusz	1	Gogolin Beds (limestone) warstwy gogolińskie (wapienie)	10.0	0.081	0.21	4.48	8.4×10^{-3}
	2		10.0	0.020	0.30	0.72	4.9×10^{-5}
	3		10.0	0.0046	0.92	0.86	2.6×10^{-4}
	4		10.4	0.231	1.75	3.45	3.2×10^{-2}
	5		10.0	0.032	0.44	1.62	8.1×10^{-4}
	6		10.0	0.030	0.22	2.00	7.9×10^{-4}
	7		10.0	0.018	0.30	1.05	1.6×10^{-4}
	8		10.0	0.022	0.51	0.55	3.7×10^{-5}
	9		1.0	0.075	1.32	0.93	4.7×10^{-4}
	10		1.64	0.20	3.29	0.83	8.2×10^{-4}
	11		1.0	0.30	3.58	1.42	4.5×10^{-3}
	12		1.0	0.13	2.66	0.60	2.5×10^{-4}
Pomorzany	1	Gogolin Beds (limestone) warstwy gogolińskie (wapienie) ore-bearing dolomite dolomit kruszchoński	2.0	0.660	14.68	0.69	1.8×10^{-3}
	2		8.0	0.120	4.16	1.03	1.7×10^{-3}
	5		3.0	0.250	7.72	0.55	6.0×10^{-4}
	3		6.0	0.340	7.96	0.86	2.0×10^{-3}
4	6.0	0.070	2.46	0.57	1.7×10^{-4}		

carried out in the Pomorzany Mine are in agreement with the results of analogous investigations by Nguyen-Khac-An (1971) and by Górecki (1977), carried out in the neighbouring Bolesław Mine.

The agreement of the results of our investigations with those carried out in other areas of the occurrence of the Cracow-Silesia Triassic has been also confirmed by literature data cited by Górecki (1978).

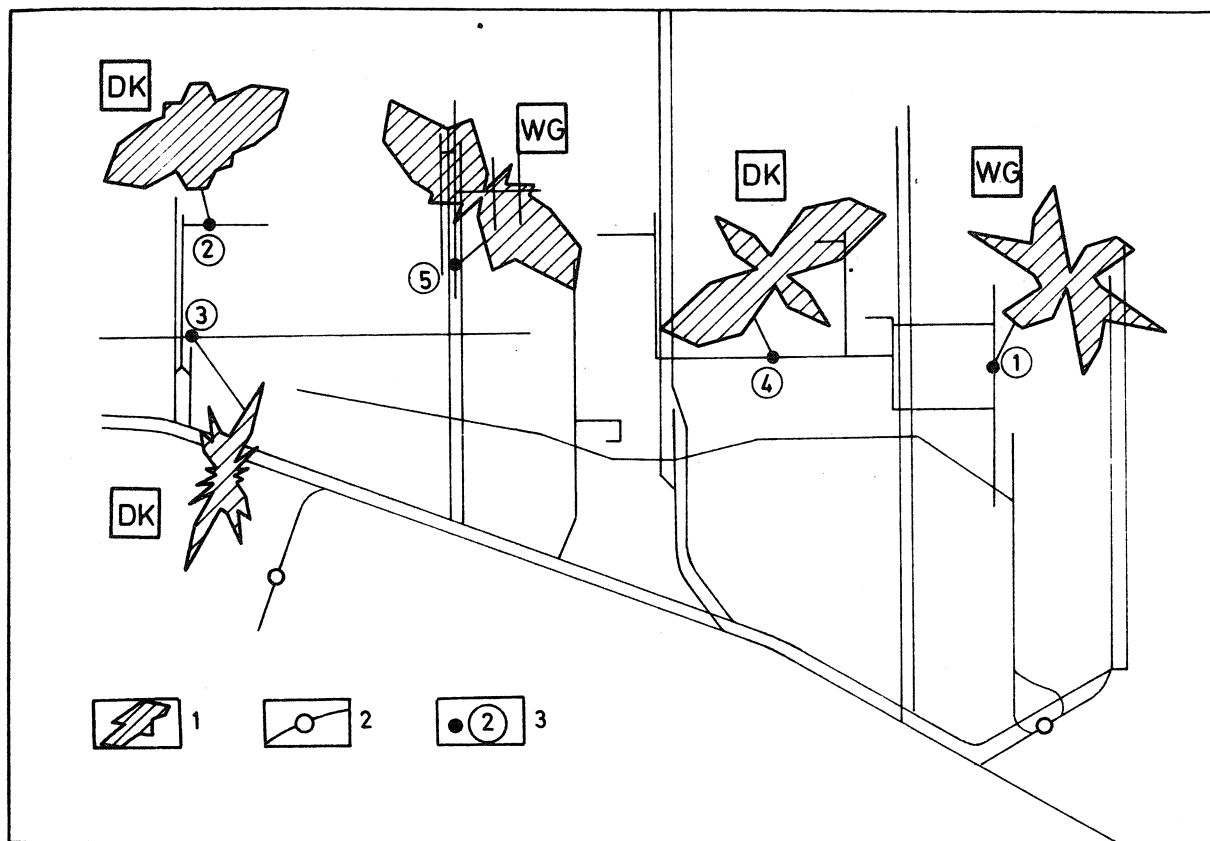

Fig. 5. Directions of joints in the Muschelkalk in the Pomorzany Mine. 1 – diagram showing the directions of joints; 2 – mine workings; 3 – measurement site with the successive number; DK – ore-bearing dolomite; WG – limestone of the Gogolin Beds

Fig. 5. Kierunki spękań w skałach wapienia muszlowego w kopalni Pomorzany. 1 – diagram kierunkowy spękań; 2 – wyrobiska kopalniane; 3 – stanowisko pomiarowe z kolejnym numerem; DK – dolomit kruszonośny; WG – warstwy gogolińskie

The joints in the examined fragments of the ore-bearing dolomite and limestone of the Gogolin Beds in the Pomorzany Mine are characterized by a prevailing deep inclination, most often ca 70–80°. Less frequent are the fissures of small inclination angles from zero to nearly 30° (Fig. 4).

A visual comparison of the diagrams of the directions of joints in the particular measurement sites shows a marked differentiation of those directions. To verify the hypothesis of the similarity or difference in the distribution of the directions of joints in the examined fragments of the Triassic rocks we applied the non-parametric D-test of Smirnow-Kolmogorow. A similarity in the distribution of the directions of joints was found only between the measurement sites Nos 1

and 5 and between 2 and 4 (Fig. 5). Between the other sites there were found statistically essential differences in the direction distributions of joints.

The measurement points Nos 1 and 5 were localized within the Gogolin Beds, while sites Nos 2 and 4 were within the ore-bearing dolomite. The measurement site 3 which was marked by a distinct difference in the distribution of the fissure direction was situated in the bottom of the ore-bearing dolomite in a transition zone to the limestone of the Gogolin Beds. The results of the measurements and a comparison of the distributions of the directions of joints, in the

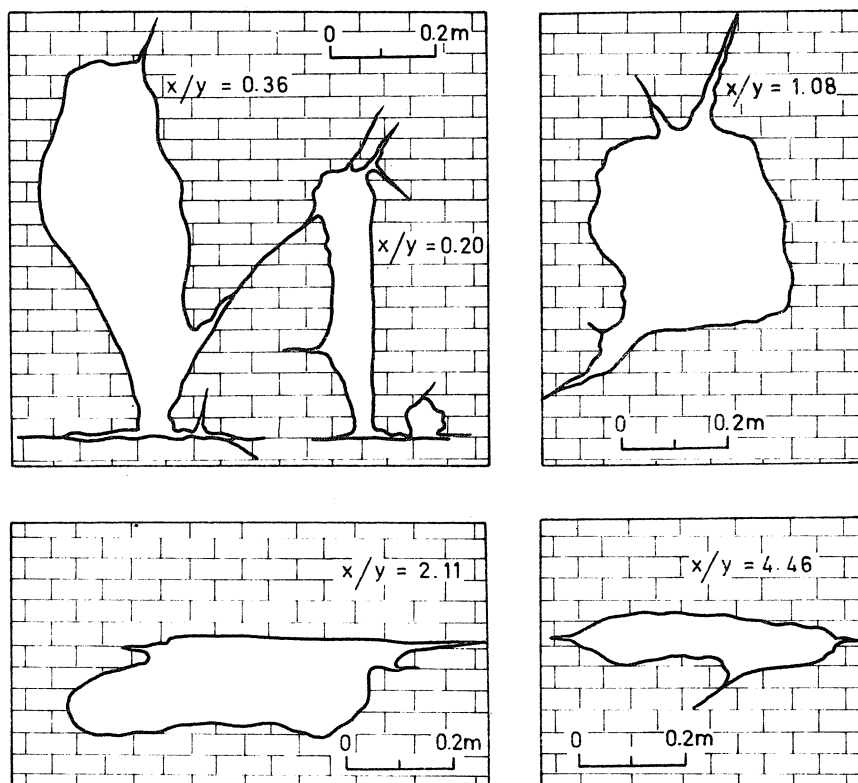

Fig. 6. Examples of shapes of the cross-sections of karst channels in the Olkusz Mine

Fig. 6. Przykłady kształtów poprzecznych przekrojów kanałów krasowych w kopalni Olkusz

authors' opinion, are essential enough to put forward a working hypothesis that the distributions of the joints direction in the limestone of the Gogolin Beds and in the ore-bearing dolomite show essential difference. Thus we may assume that the carbonate Triassic rocks in the region of the Pomorzany Mine display an anisotropy of fracture orientation which is changing along with the vertical profile. The above hypothesis, however, must be verified by carrying out a considerably greater number of measurements of the directions of joints in the examined rock massif.

A special consideration should be given to the distribution of the directions of joints in the measurement site No 2, localized within the ore-bearing dolomite (Fig. 5). The examined fragment of the rock massif is characterized by a uniform distribution of the directions of joints, which is typical for the collapse breccia structures of this region, described by Sass-Gustkiewicz (1974), resulting from a chaotic arrangement of fractures in these structures. A similar distribution of

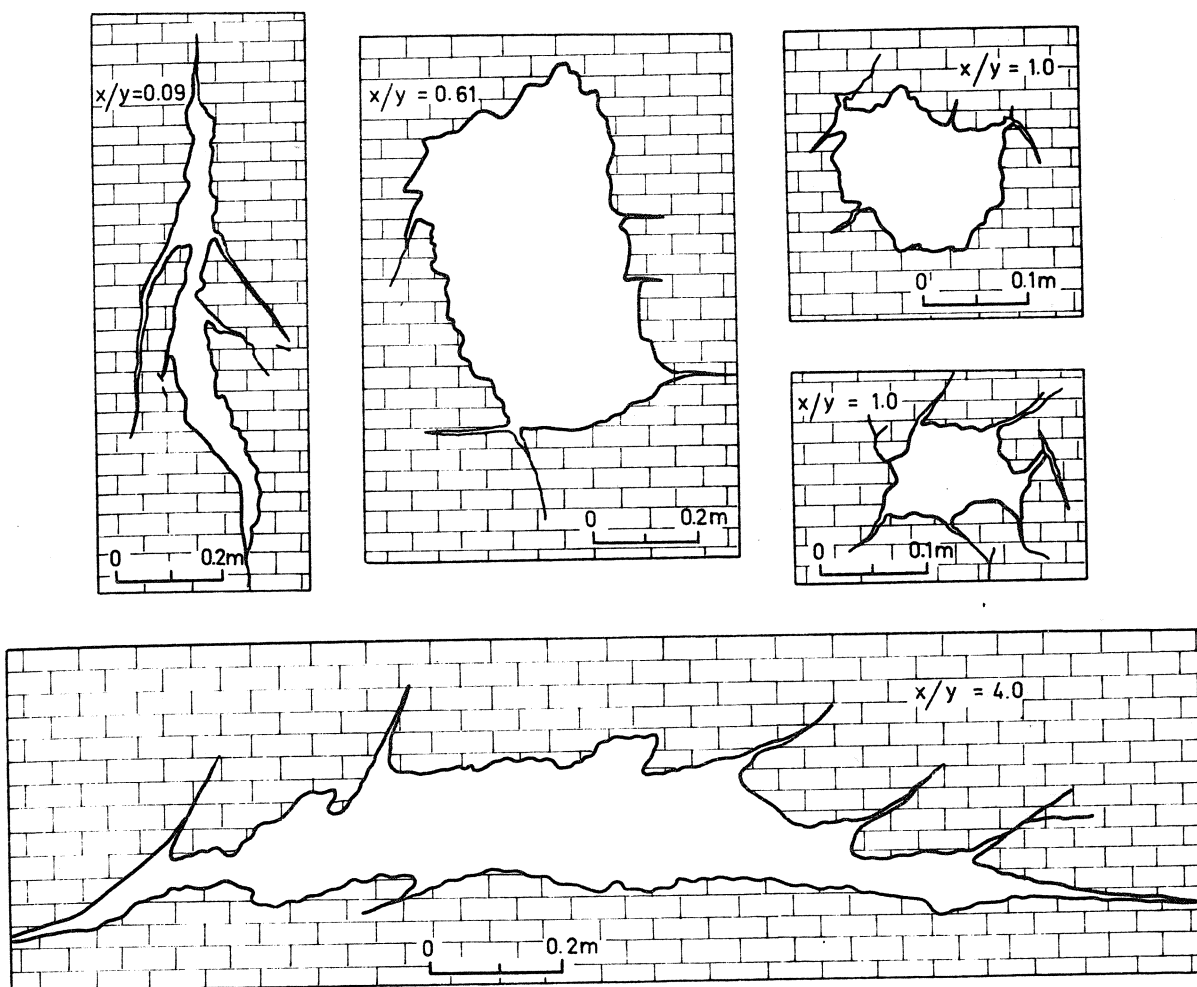

Fig. 7. Examples of shapes of the cross-sections of karst channels in the Pomorzany Mine
Fig. 7. Przykłady kształtów poprzecznych przekrojów kanałów krasowych w kopalni Pomorzany

joints has been found by Krokowski (1974) in the limestone of the Gorazdże and Gogolin Beds in the region of the village Płaza near Chrzanów.

Important features of karst passages from the point of view of hydraulic resistance of water flow are: shape, size and variability of their cross-section. At the present stage of investigations there have been collected data concerning the shape and the surface area of intersection of open karst forms with a side wall of a mine working in the Olkusz and Pomorzany Mines. The total number of measurements of the shape and surface area of the cross-section of open karst voids was 62, out of which 25 were carried out in the Olkusz and 37 in the Pomorzany Mines.

The shapes of the examined cross-sections were as a rule very irregular (Figs. 6, 7). A characteristic feature of the encountered karst passages are their very uneven walls (Figs. 6, 7) what may indicate that their formation was greatly influenced by the solution process. Channels with smoothed walls of karst pipe type were very rare. Their formation was most probably much affected by the process of mechanical widening of the channel. Some channels evidently have their roof and/or floor formed by bedding planes (Figs. 6, 7).

The cross-sections of the karst channels under consideration were transformed

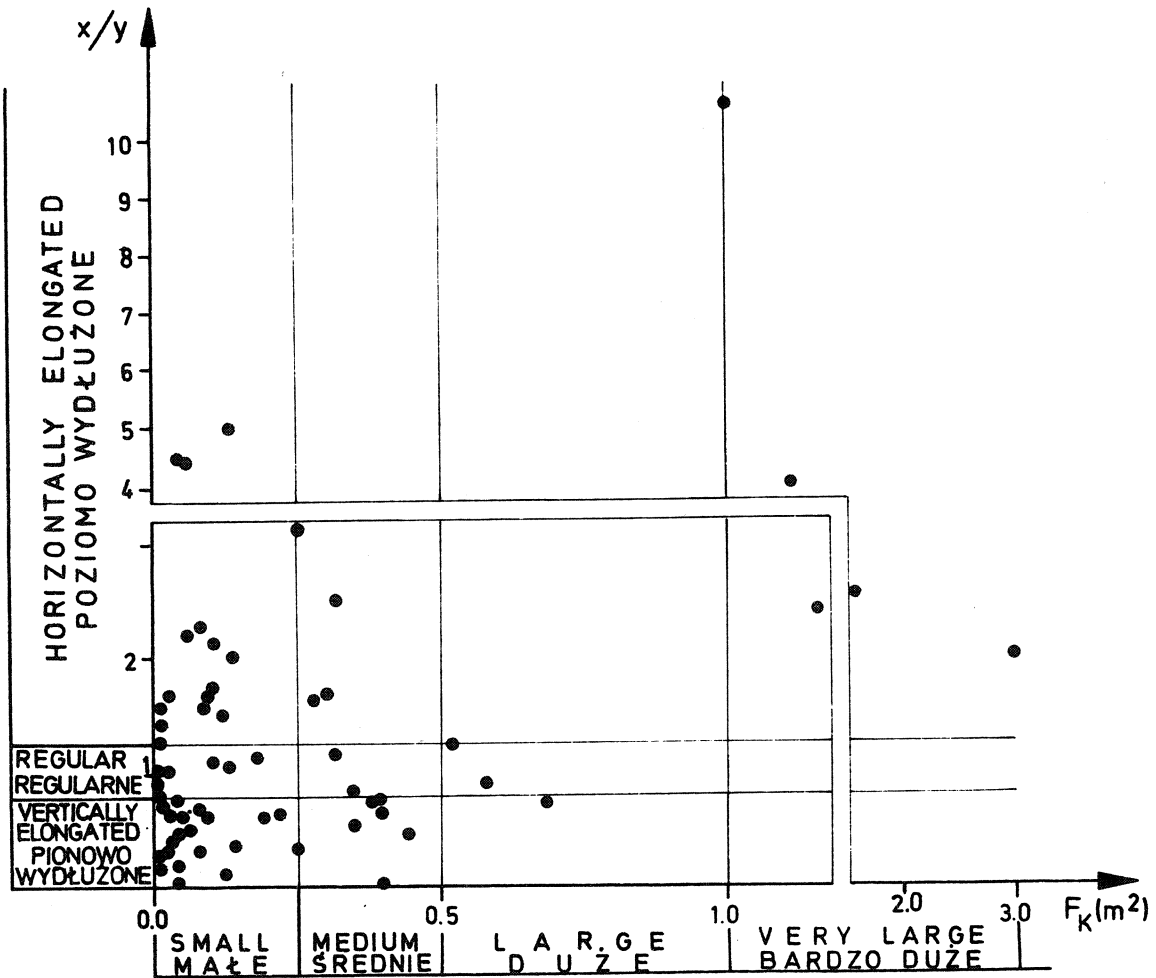

Fig. 8. Relation between the ratio of the lengths of the halfaxes x/y of karst channel cross-sections and the size of their area (F)

Fig. 8. Związek między stosunkiem długości półosi x/y poprzecznych przekrojów kanałów krasowych i wielkością powierzchni (F) tych przekrojów

to equivalent (with respect to the size of their surface area) ellipses and as a regularity measure of the given cross-section we assumed the ratio of the horizontal half-axis of the ellipse and its vertical half-axis (Formula 5). The results of the calculation of the surface area of the examined cross-sections and the quantitative relationship of the half-axes of the equivalent ellipses are shown in Fig. 8.

The cross-section surfaces of the observed karst channels are found within a wide range of values from 0.002 to 3 m². With respect to the size of this surface (F_k) we accepted the provisional division of the examined karst channels into four groups:

- | | |
|----------------|------------------------------------|
| I. small | $F_k \leq 0.25 \text{ m}^2$ |
| II. medium | $0.25 < F_k \leq 0.50 \text{ m}^2$ |
| III. large | $0.50 < F_k \leq 1.0 \text{ m}^2$ |
| IV. very large | $F_k > 1.0 \text{ m}^2$ |

This division is not to be compared with those proposed by other authors. Most frequent classifications – even if they take into consideration the dimensions of subterranean karst forms with respect to the amount of possible flow

and the subsequent water hazard in the mine – contain only a verbal description of the distinguished classes or groups (e.g. Borevskij et al., 1976). On the other hand, divisions based on numerical data refer to surficial karst forms (e.g. Liszkowski, 1967).

It can be easily seen from Fig. 8 that karst channels of small cross-section form the dominating group. This refers to both the examined stratigraphic units, i.e. the Gogolin limestone and the ore-bearing dolomite and the two mines in which observations were made.

The ratios of the half-axes of equivalent ellipses which are the regularity measure of the cross-section of a karst channel occurred within the interval 0.09–10.6. Taking as a basis the values of these ratios we distinguished three main types of the investigated forms:

1. vertically elongated – the ratio of the lengths of half-axes less than 0.75
2. regular – the ratio of the lengths of half-axes 0.75–1.25
3. horizontally elongated – the ratio of the lengths of half-axes greater than 1.25

Karst channels with a cross-section vertically elongated constituted 40% of all

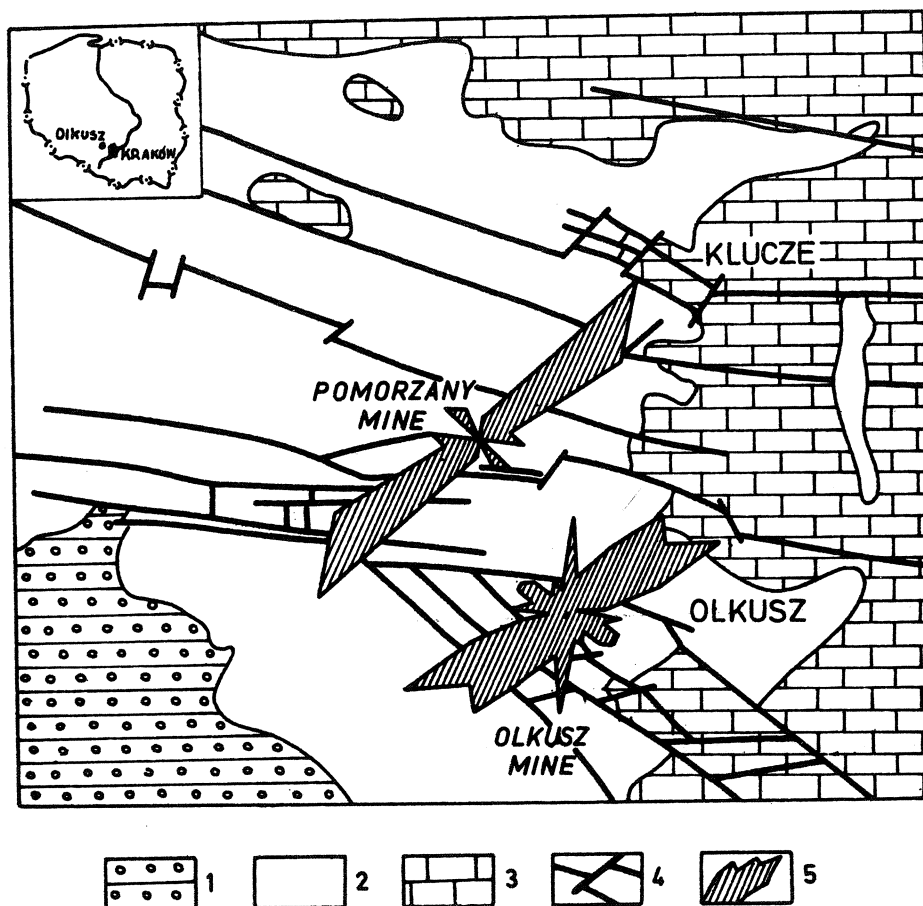

Fig. 9. Directions of karst channels in the Triassic in the ore mines of the Olkusz district against the background of the geological map of the region. 1 – Permian, 2 – Triassic, 3 – Jurassic, 4 – tectonic-fault, 5 – diagrams showing the directions of karst channels

Fig. 9. Kierunki kanałów krasowych w węglanowych osadach triasu w olkuskich kopalniach rud¹ na tle mapy geologicznej rejonu. 1 – perm, 2 – trias, 3 – jura, 4 – uskoki, 5 – diagramy kierunkowe kanałów krasowych

the examined forms, channels with a regular cross-section – 23%, and those with a horizontally elongated cross-section – 37%.

In the Pomorzany Mine we noted a rather distinct regularity in that the horizontally elongated forms are more frequent in the ore-bearing dolomite, and the vertically elongated ones – in the Gogolin limestones. The other regularity which has been observed is the relation between the shape of the cross-section of karst channels and their size (Fig. 8). Channels with very large cross-sections are horizontally elongated what is an indication that they have developed on bedding planes. The small and medium forms show great variation in shape, nevertheless it is worth noticing that some of these channels have developed on steep joints and hence they are strongly elongated vertically.

The directions of the particular karst channels are various, what is generally characteristic of a developed network of this type of karst forms. Nevertheless, among all the possible directions the 40–80° direction is the most distinct one both in the Olkusz and the Pomorzany Mines (Fig. 9). The main trend of karst channels does not correspond to the directions of the main disjunctive dislocations, i.e. WNW–ESE in the region of the Pomorzany Mine and NW–SE in the region of the Olkusz Mine (Fig. 9), whereas it resembles the most frequently occurring direction of joints of the carbonate sediments of the Cracow-Silesia Triassic.

HYDRAULIC CHARACTERISTICS OF THE EXAMINED SYSTEM OF FRACTURES AND CAVITIES

HYDRAULIC MODEL OF THE TRIASSIC WATER-BEARING HORIZON

In the karst-fissured, carbonate Triassic rocks in the Olkusz region we can distinguish the following hydraulic systems: pores, fissures, open karst voids and filled karst cavities (Fig. 10). The above mentioned systems form the inner hydraulic structure of the examined rock medium. It is necessary to note at this point that the hydraulic features of the inner structure of the examined medium may undergo changes due to groundwater circulation.

The principal element of the outer hydraulic structure of the Triassic water-bearing horizon in the Olkusz ore-mining region are numerous dislocations which divide that aquifer into separate hydrogeological units. The recharge or discharge of the Triassic aquifer by other water-bearing horizons in the zones of hydraulic contacts are also an important element (Wilk, Motyka, 1977) and this should also be taken into consideration when constructing a general hydraulic model of the investigated aquifer (Fig. 10).

The pore space in the carbonate Triassic rocks has been the subject of another paper by the authors (Wilk, Motyka et al., in press) while the selected features of fissures and open karst passages were discussed in the preceding chapter. Thus we should now discuss the filled karst cavities.

On the basis of observations carried out up to now we can assume that the clogged karst cavities constitute a considerable volume of the massif of the

carbonate Triassic rocks. In the galleries of the mines in the Olkusz ore district one can encounter vast zones of secondarily filled karst passages as long as several hundreds of meters (cf. e.g. Wilk et al., 1973).

According to Sass-Gustkiewicz (1974) the discussed forms came to being mainly as a result of collapsing of large karst systems forming collapse breccia structures. The substance filling these forms is made up chiefly of grained carbonate material in which sharp-edged fragments and blocks of Triassic carbonate rocks

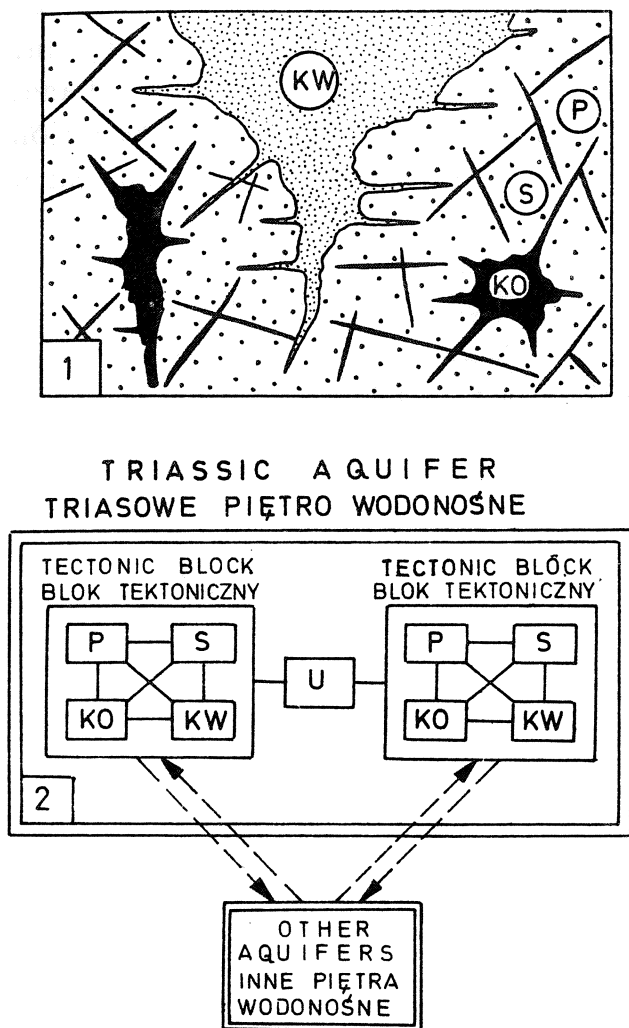

Fig. 10. Hydraulic model of the Triassic aquifer. 1 - scheme of a rock massif fragment, 2 - hydraulic scheme of groundwater circulation, P - pore space, S - fissures and joints, KO - karst voids not filled with mineral matter (open), KW - karst forms secondarily filled with mineral matter (clogged), U - fault

Fig. 10. Model hydrauliczny triasowego piętra wodonośnego. 1 - schemat fragmentu masywu skał triasowych, 2 - schemat hydrauliczny krążenia wód podziemnych, P - przestrzeń porowa, S - szczeliny i spękania, KO - nie wypełnione substancją mineralną (otwarte) kanały krasowe, KW - wtórnie wypełnione substancją mineralną formy krasowe, U - uskoki

of various size are stuck (Sass-Gustkiewicz, 1971). We can observe here the regularity in that the proportion of the boulder fraction and rock waste is greater in the upper section of these structures (Figs. 11, 12). In the collapse breccia structures the concentrations of zinc, lead and iron sulphides are very common (Sass-Gustkiewicz, 1974). Sometimes the karst cavities are filled with carbonaceous substance with the remnants of *Arthropoda* (Lipiarski, 1971) or with colloidal zinc sulphide (brunckite) or a clayey substance. Sporadically we can find forms filled with iron oxides with hematitic pizolites stuck in them.

The problem of water flow through an internally heterogeneous medium has been solved theoretically for fissured rocks (Barenblatt, Żeltow, 1960; Streltsova, 1976). What regards water-flow in karst-fissured massifs Liszkowski (1977)

proposed some preliminary theoretical assumptions, which, however, are concerned mainly with the evolution of internal hydraulic structure in those massifs due to the movement of ground water. Under natural conditions the process of remodelling this structure proceeds very slowly and for problems of hydrogeological practice it appears necessary to work out a qualitative and quantitative model of the groundwater exchange between the particular types of voids in the karst-fissured rocks. The authors of the present paper have confined themselves to the discussion of a qualitative model (Fig. 10).

When discussing the model of the inner hydraulic structure of a karst fissured massif we should first of all take into consideration the rôle played by the particular types of voids in the groundwater flow through the medium of that type. This problem in hydrogeological literature is still open for discussion (Király, *op. cit.*). What regards the pore space there prevails the opinion that it

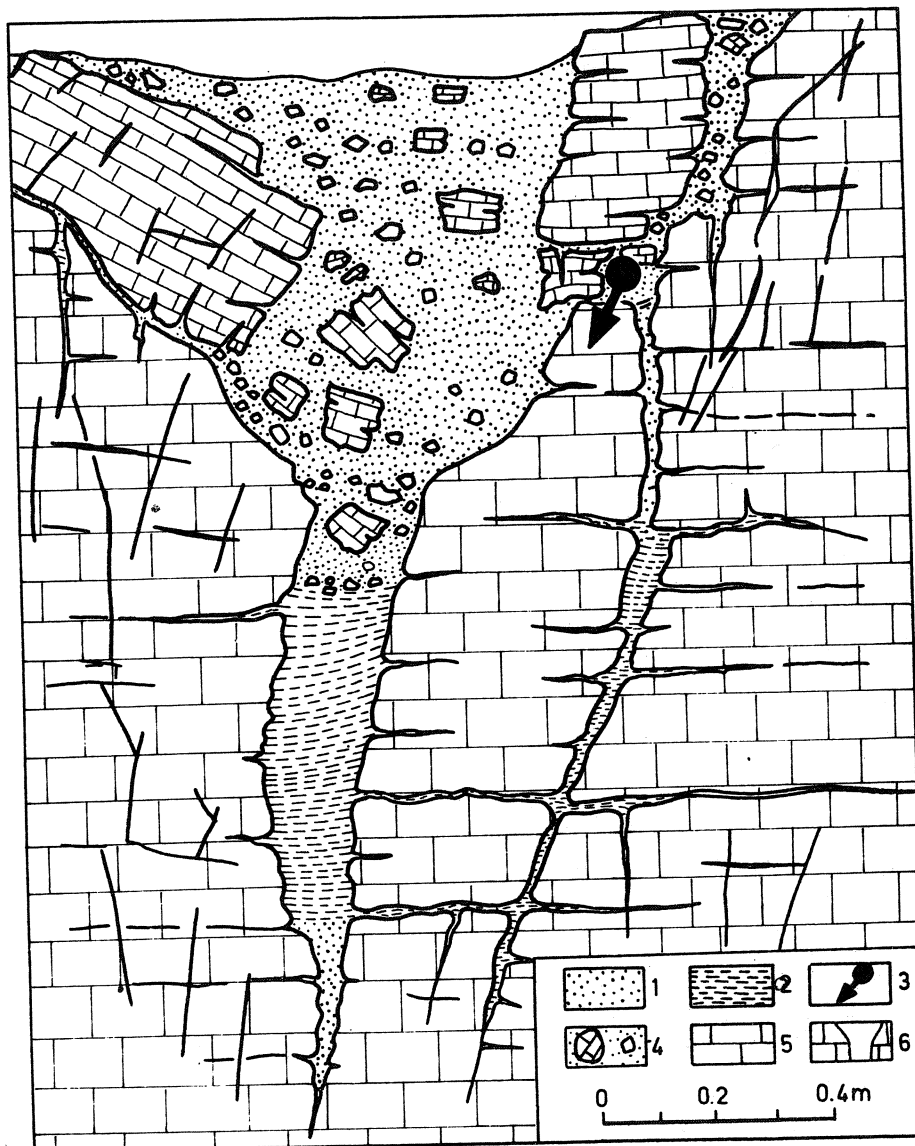

Fig. 11. Example of filled karst form with water discharge (Olkusz Mine). 1 - sand, 2 - silt, clay, 3 - breccia, 4 - limestone, 5 - groundwater outflow, 6 - unfilled karst void

Fig. 11. Przykład wypełnionej formy krasowej z wypływem wody (kop. Olkusz). 1 - piasek, 2 - zdiagenezowany il, 3 - brekcja, 4 - wapienie, 5 - wypływ wody podziemnej, 6 - nie wypełniona pustka krasowa

functions as an underground water store. The hydraulic resistance of water flow in pores in comparison with that in the fissures and karst channels is very great and due to this fact Barrenblatt and Želtow (*op. cit.*) have assumed, for the sake of simplifying the mathematical model of a fissured rock, that the porous space is practically impermeable, possessing only a very limited hydraulic storativity. However, Streltsova (*op. cit.*) opposes such simplification and she maintains that in a general mathematical model of flow through the medium under consideration the permeability of pore passages cannot be neglected.

Due to relatively small hydraulic resistance and the distribution throughout the whole rock massif – the joints, fractures and fissures are the principal circulation paths of groundwater in fissured and karst-fissured media. The network of fissures can be compared to the mesoporosity of the massif, in which blocks of rock separated by fractures behave like grains in a typical porous medium. The volume taken up by fissure voids in a massif is very small and usually does not exceed 1%. Hence, Streltsova (*op. cit.*) maintains that these are, first of all, hydraulic conduits of high transmissivity and of very small or practically no storativity.

Open karst channels may be regarded as analogous to fissures having only very small hydraulic resistance in comparison with other types of voids and on account of very limited proportion of their volume in the total volume of the rock massif – also very small storativity. On this account the karst passages con-

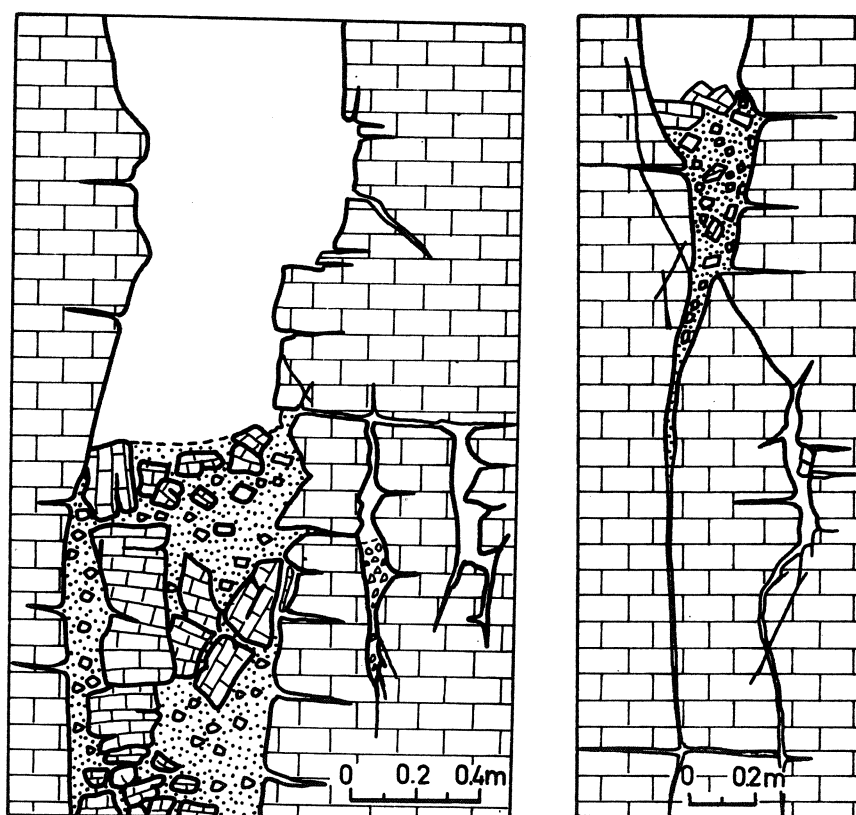

Fig. 12. Examples of partly filled karst forms (Olkusz Mine). To the left – partly filled karst well.
To the right – karst voids developed on vertical fissures

Fig. 12. Przykłady częściowo wypełnionych form krasowych (kop. Olkusz). Na lewo – częściowo wypełniony komin krasowy. Na prawo – kanały krasowe rozwinięte na pionowych szczelinach

stitute the most privileged circulation paths of groundwater in the saturation zone and they can be compared to a stream network on the ground surface. Under natural conditions these forms may function as the local, internal drainage basis of a rock medium (e.g. Haładus et al., 1978). The rôle of open karst channels is distinctly visible in case of a disturbance of natural flow conditions by mining activity. On the one hand, they are the source of sudden, unexpected inrush of great volume of water into the mining galleries (Wilk et al., 1977), on the other hand they may influence the shape of a depression cone around the mine or large water-well systems.

The filled karst forms combine the features of a pore space, fissures and open karst and this fact makes them different from other forms. Depending on the type of the filling material, the degree of its consolidation and the intensification of the crystallization process of the binding material the discussed forms may be characterized by hydraulic conductivity similar to that of a pore space, fissures or even open karst channels of small cross-section. What regards the hydraulic storativity of the filled karst forms — it is not easy to express an opinion considering the present state of investigations in this field. The rôle of those systems becomes especially important in case of a disturbance of the natural groundwater regime. The artificial lowering of the natural water table causes first of all an increase of the hydraulic gradients and as a result the suffosion process as well as the displacement of the material filling the karst cavities are initiated or intensified. In effect, the internal structure of karst-fissured rocks becomes remodelled, i.e. the filled passages are emptied locally or the fractures and open karst passages become clogged.

TRANSFORMATION OF A FRACTURED ROCK MEDIUM INTO A POROUS ONE WITH RESPECT TO ITS WATER PERMEABILITY

The methods of hydrogeological calculations with regard to fractured rocks can be divided into four principal groups:

1. Methods based on the results of experimental laboratory investigations of water flow through the fractures (Wołodko, 1941; Łomize, 1951; Baker, 1956; Romm, 1966; Żilenkow, 1967; Wittke, Louis, 1968).

2. Hydrodynamic methods based on the assumptions, that a fractured rock is composed of two overlying, pore and fractured, continuous media, wholly saturated with the moving water, and that the flow in both media is subject to Darcy's Law (Barenblatt, Żeltow, 1960; Streltsova, 1976).

3. Methods regarding fractured rocks as an anisotropic, homogeneous medium i.e. according to Hantush (1966) such one, in which its hydraulic transmissivity is exclusively a function of direction. The representatives of this approach are e.g. Gawicz (1966), and Herbich, Krajewski (1977).

4. Methods regarding fractured rocks as a porous medium i.e. based on the assumption that the equations describing the flow of fluid in these rocks are identical

with those describing fluid flow in a pore space (Śmietański, 1969: Babuszkin i in., 1972).

Practical application of the first two of the above mentioned methods requires the knowledge of such geometrical characteristics of fractures as: width, length, direction and roughness or hydraulic properties of the pore space and crackings. These informations can be obtained only by way of laborious laboratory investigations and direct observations in natural or man made exposures.

When applying the third method it is necessary to identify the main axes of hydraulic transmissivity of the examined medium, what is in principle only possible on the basis of the results of pumping tests.

For the above reasons, when carrying out hydrogeological calculations in practice, methods are applied which regard fractured rocks as a porous medium. With this in mind the authors have found it interesting to compare the values of the filtration coefficients of the Muschelkalk in the Olkusz region, obtained on the basis of the results of test pumpings with the values of this hydraulic parameter obtained by means of another procedure using the knowledge of the geometrical characteristics of fractures. Such a rough comparison is possible after a transformation of the examined portion of a fractured rock massif into a porous medium, i.e. after assuming that the rate of water flow through the cross-section of this portion (Q_m) is equal to the water flow through a porous medium of identical cross-section (Q_p):

$$Q_m = Q_p \quad (6)$$

It also has to be assumed that the hydraulic gradient is the same in all fractures and in an equivalent (with respect to the intensity of flow) porous medium. The latter assumptions are the most controversial. The assumption that the hydraulic gradient is equal is correct only with respect to a massif divided by a system of parallel joints of identical width. Considerable differences may appear in case of great differentiation in the width of fractures.

It is difficult to give a definite opinion whether the assumption of identical hydraulic gradient in the fractures and in an equivalent porous medium is correct. It is known that in fractures of great width the hydraulic gradient is relatively small on account of small flow resistance. At the same time to a massif divided by a network of wide fractures there corresponds an equivalent porous medium with a great filtration coefficient. In rocks characterized by a great filtration coefficient (such as gravel or rubble) the hydraulic gradient is not great either.

Nevertheless, the authors, still proceeding cautiously, believe that the value of the filtration coefficient calculated by means of formula (8) is only a rough approximation.

Introducing Darcy's Law in its most common form and Boussinesq' equation (3) into (6) and taking into consideration the width of the fractures we obtain:

$$\frac{g \cdot J}{12\nu} \sum \frac{b_i^3 \cdot l_i}{B_i} = k \cdot J \cdot F \quad (7)$$

Having considered the kinematic viscosity of water at a temperature of 10°C and accepting the simplifying assumption that the ratio $e/b = \text{const} = 0.2$ we obtain the following formula for the mean value of the filtration coefficient

$$k = 4.42 \cdot 10^5 \cdot \frac{\sum b_i^3 \cdot l_i}{F} \quad (8)$$

The results of calculation of the filtration coefficients using formula (8) for the particular portions of the examined carbonate rocks are listed in Table 1. It can be seen that the values of the filtration coefficients obtained in this way are close to the values of this parameter obtained on the basis of the results of test pumpings in the Muschelkalk in the same region (Motyka, Wilk, 1976).

HYDRAULIC RESISTANCE OF KARST PASSAGES REGARDED AS CONDUITS OF CIRCULAR CROSS-SECTION

In hydrogeological literature dealing with water flow in karst passages it is pointed out that hydraulic resistance in this type of voids is rather small. To the authors knowledge exceptionally only information can be found so far in the literature about the value of this resistance even if roughly estimated (Atkinson, 1977). For this reason the authors decided to make an attempt of an approximate calculation of hydraulic resistance in karst channels of a nearly circular cross-section (Fig. 6, 7, 8), basing on the known empirical formulae (Colebrook, White, 1937; Troskolański, 1962).

A measure of the magnitude of a hydraulic resistance is the coefficient of hydraulic friction as one of the factors on which the magnitude of hydraulic losses depend, the other factors being the diameter and the length of the channel, as well as the flow rate of the fluid. This coefficient is an empirical, dimensionless value, depending on the diameter of the passage, the roughness of its inside walls and on the type and flow rate of the fluid.

Troskolański (*op. cit.*) presents, among others, the following formulae of Mises (9) and Colebrook and White (10) used to calculate the coefficient of hydraulic friction:

$$\lambda = \left(0.0096 + \sqrt{\frac{16w}{d_z}} \right) \left(1 - \frac{Re_{kr}}{Re} \right) + \frac{1.7}{\sqrt{Re}} \sqrt{1 - \frac{Re_{kr}}{Re}} + \frac{32}{Re} \quad (9)$$

$$\frac{1}{\sqrt{\lambda}} = -2 \lg \left[\frac{2.51}{Re \sqrt{\lambda}} + \frac{w}{3.72d_z} \right] \quad (10)$$

To calculate the hydraulic resistance making use of formulae (9) and (10) it is necessary to know the value of Reynolds number (Re) and the absolute roughness for karst channels walls. To apply Mises' formula we must also know

the critical value of Reynolds number (Re_{kr}). It can be calculated only when the velocity of flow is known. However, the last one it is very difficult to assess.

Practically, the possibility of a direct measurement of water flow through karst channels by hydraulic methods or by an indirect method with the application of tracers – is very small. The latter method, when applied on a large scale, often enables to carry out measurements in a whole, complicated system of fissures and karst voids instead of a single channel. Hence it is difficult to find in the literature any information about the flow rate of water in single karst channels, especially those of small cross-section and situated in the saturation (phreatic) zone. The determination of the height of individual protrusions on the walls of a karst channel (absolute roughness) is not an easy task either, considering the irregular line of its cross-section (Figs 6, 7).

The value of the coefficient of hydraulic friction for some karst channels selected by way of example was calculated by the method of successive approximations, utilizing formulae (9), (10) and de Chezy's formula for the flow rate in a conduit of a circular cross-section:

$$v = \sqrt{\frac{2g \cdot J \cdot d_c}{\lambda}} \quad (11)$$

It has been assumed approximately that in small karst channels the hydraulic gradient equals $J = 0.0005$, in channels of medium size $J = 0.0001$, and in large ones $J = 0.00005$. The critical value of Reynolds number occurring in formula

Table – Tabela 2
Hydraulic resistance of karst passages regarded as conduits
of circular cross-section

Opory hydrauliczne kanałów krasowych traktowanych jako przewody
o przekroju kołowym

Channel No Numer kanału	Cross-section area of the channel F_k (m ²)	Channel diameter d (m ²)	Flow rate (m/s)	Reynolds number Re	Absolute roughness (m)	Coefficient of hydraulic friction λ according to formula by	
						Mises	Colebrooke-White
2	0.176	0.47	0.03	10760	0.03	0.99	0.083
3	0.317	0.64	0.04	19540	0.02	0.72	0.060
6	0.104	0.36	0.06	16490	0.025	1.05	0.085
8	0.383	0.70	0.04	21910	0.03	0.83	0.068
16	0.003	0.062	0.03	1280	0.005	0.85	0.104
17	0.0024	0.055	0.025	1050	0.005	0.82	0.111
24	0.124	0.40	0.07	21680	0.015	0.78	0.064
30	0.350	0.67	0.03	16880	0.06	1.19	0.096
39	0.010	0.11	0.03	2690	0.01	1.08	0.102
47	0.020	0.16	0.04	4890	0.01	0.96	0.083
48	0.580	0.86	0.03	20350	0.04	0.87	0.070
58	0.009	0.11	0.03	2270	0.02	1.46	0.151

(9) was assumed after Kerkis (1975), according to whom it is contained within the interval 300–500. The medium value of this interval, i.e. $Re_{kr} = 400$ was used in the formula. The absolute roughness of the walls of the channels was estimated on the basis of their visual inspection and direct measurements.

The values of the coefficients of hydraulic friction calculated using formulae (9) and (10) for selected cylindrical karst channels are put together in Table 2.

It follows from Table 2 that the values of the coefficient of hydraulic friction calculated by means of formula (9) differ by an order of magnitude from those calculated using formula (10). Hence it may be concluded that, besides the above mentioned difficulties in determining the flow rate, the final calculated value of the coefficient of hydraulic friction may be affected by the choice of the calculation formula.

The determination of the coefficient of hydraulic friction of karst channels is not an easy task, though it is important e.g. for greater accuracy of the prognosis of the amount of water inflow in a mine working from a single karst channel. The present state of investigations in the Olkusz ore mine enables only an approximate determination of the value of this coefficient. It is the task for the future to strive to obtain a more precise evaluation of the rate of water flow in karst channels by indirect methods. The same refers to a more accurate determination of the value of hydraulic gradient in karst channels by appropriate location of piezometric bore-holes.

CONCLUSIONS

The distribution of the width of fractures observed in the underground mine workings of the Olkusz and Pomorzany Mines driven in the Muschelkalk is assymmetric. The maximum measured width is 5 mm and the most frequent one is about 0.2 mm. The number of fractures of greater width decreases with increasing depth of the mine workings. The equivalent width of fractures is between 0.55 and 4.48 mm. The coefficient of fracture porosity is between 0.0046 and 0.66%, whereas the areal frequency (density) of fractures between 0.21 and 14.7 m^{-1} .

The roughly approximated values of the coefficient of filtration (hydraulic conductivity) of the rock massif under investigation were calculated using formula (8) derived by the authors. These are between 4.9×10^{-5} and 3.2×10^{-2} m/s and are close to the values of this parameter obtained on the basis of the pumping tests carried out in the Muschelkalk of the same region.

The cross-sectional area of the surveyed karst solution openings was found to be within 0.002 and 3 m^2 . The cross-sections of the karst channels were transformed to equivalent (with respect to the size of their surface area) ellipses. The ratios of the halfaxes of equivalent ellipses occurred within the interval of 0.09 and 10.6. Karst channels with their cross-sections vertically elongated (developed on joints?) constituted 40% of all the examined voids, channels with a regular (nearly circular) cross-sections – 23%, and those with horizontally elongated cross-sections (developed on bedding – planes?) – 37%.

Making simplified assumptions the friction coefficients of some selected karst channels were calculated by the method of successive approximations using de Chezy's (11), Mises' (9) and Colebrook – White's (10) formulae. The approximate values of this coefficient calculated using formula (9) differ by one order of magnitude from those calculated using formula (10). The values of λ calculated using Mises' formula are between 0.72 and 1.46, whereas those calculated according to Colebrook – White's formula are between 0.064 and 0.151.

Further field and laboratory investigations of the hydraulic parameters of fractures and karst solution openings are necessary in order to meet the practical needs of the ore mining concerning e.g. more accurate predictions of mine water inflow. They should comprise among others the measurements of the rate of water flow in karst channels by indirect methods and the determination of actual hydraulic gradients in karst channels by appropriate location of piezometers.

ACKNOWLEDGEMENTS

The authors are indebted to Prof. Dr St. Dżułyński who was kind enough as to read the manuscript and to discuss with us the English karst terminology used in the paper. We also acknowledge the criticism of Dr J. Liszkowski who was the editorial reviewer of the paper. We made use of some of his critical remarks.

REFERENCES – WYKAZ LITERATURY

- Actes do colloque de Dubrovnik (1967). Hydrologie des roches fissures. Vol. I et II. AIHS-Unesco, Louvain, pp. 420.
- Atkinson T.C. (1977), Diffuse flow and conduit flow in limestone terrain in the Mendip Hills, Somerset (Great Britain). *J. Hydrol.* 35: 93–110.
- Bögli A. (1978), Karsthydrographie und physische Speläologie. Springer-Verlag, Berlin, Heidelberg, New York, pp. 292.
- Burger A., Dubertret L., ed. (1975), Hydrology of Karstic Terrains. Intern. Union of Geol. Sc. Series B, No 3. *International Association of Hydrogeologists, Paris*, pp. 490.
- Choquette Ph.W., Pray L.C. (1970), Geologic nomenclature and classification of porosity in sedimentary carbonates. *AAPG Bull.* 54, 2: 207–250.
- Colebrook C.F., White C.M. (1937), Experiments in fluid friction in roughened pipes. *Proc. R. Soc., Ser. A*, 161: 367–781.
- Godyń J., Kluczewski L., Niewdana J. (1976), Zabezpieczenie kopalni w warunkach dużych dopływów wody na przykładzie kopalni Pomorzany. (Protection of a mine against high water inflows on example of Pomorzany mine). *Wiad. Górnicze*, 5: 134–138.
- Górecki J. (1977), Orientacja przestrzenna i wykształcenie spękań w utworach triasowych kopalni „Bolesław” k. Olkusza. (Spatial orientation and nature of fractures from the Triassic rocks of the Bolesław mine near Olkusz). *Prz. Geol.* 11, 556–558.
- Górecki J. (1978), Górniczo-geologiczne aspekty rozpoznania tektoniki spękania górotworu karbońskiego (na przykładzie warstw libiąskich). Praca doktorska, AGH Kraków.
- Greń J. (1976), Statystyka matematyczna. Modele i zadania. PWN Warszawa, wyd. 5, s. 362.
- Haładus A., Motyka J., Szczepański A., Wilk Z. (1978), Prognozowanie metodą modelowania analogowego dopływów wody do kopalń pracujących w skałach szczelinowo-krasowych. (Forecasting of ground-water inflow into mines in fissure – karst horizons using the electric analog simulation method). *Rocz. Pol. Tow. Geol.* 48, 3–4: 559–587.
- Hantush M.S. (1966), Wells in Homogeneous Anisotropic Aquifers. *Water Res. Research*, 2, 2: 273–279.

- Herbich P., Krajewski S. (1977), Określanie horyzontalnej anizotropii warunków filtracji w utworach szczelinowych na podstawie analizy niustalonego dopływu do studzien. (Evaluation of horizontal anisotropy of filtration conditions in fissured deposits on the basis of analysis of unstable inflow to wells). *Prz. Geol.* 8–9: 454–462.
- Jakucs L. (1977), Morphogenetics of Karst Regions. Akademiai Kiadó. Budapest. pp. 284.
- Karst Hydrology. Proceedings of the Twelfth International Congress of the International Association of Hydrogeologists. Huntsville, Alabama, USA. J.S. Tolson and F.L. Dogle ed. (1977) UAH Press. Huntsville, Alabama. pp. 578.
- Kiraly L. (1975), Rapport sur l'état actuel des connaissances dans le domaine des caractères physiques des roches karstiques. (In: Burger A., Dubertret L. ed. (p. 53–67).
- Krokowski J. (1974), Statystyczne opracowanie spękań ciosowych wapieni środkowego triasu i górnej jury między Krakowem a Chrzanowem. (Statistic Elaboration of Joints in Middle Triassic and Upper Jurassic limestones between Kraków and Chrzanów). *Zesz. Nauk. AGH nr 412, Geologia* 19: 45–56.
- La Moreaux P.E., Le Grand H.F., Stringfield V.T. (1975), Progress of knowledge about hydrology of carbonate terranes (in: Burger A., L. Dubertret ed. p. 41–52).
- Lipiarski I. (1971), On Fossil Remains of Arthropods and Plants, and Organic Matter from Cavities in the Triassic Rocks of the Cracow Area. *Bull. de l'Acad. Pol. des Sci. Ser. des Sci. de la Terre.* 19, 2: 79–83,
- Liszkowski J. (1967), Podstawy klasyfikacji zjawisk i procesów krasowych dla potrzeb praktyki inżyniersko-geologicznej i hydrogeologicznej. (Principles of classifications of karst phenomena for engineering-geological and hydrogeological purposes). *Prz. Geol.* 5: 225–230.
- Liszkowski J. (1977), Prawidłowości i odrębności hydrauliki krasowej. (Regularities and peculiarities of karst hydraulics). *Biul. Geol. UW*, 21: 29–51.
- Liszkowski S. Stochlak J. (red.), (1976), Szczelinowatość masywów skalnych. WG Warszawa, pp. 312.
- Motyka J., Wilk Z. (1976), Pionowe zróżnicowanie wodoprzepuszczalności węglanowych skał triasowych w świetle statystycznej analizy wyników próbnych pompowań (monoklina śląsko-krakowska), (Vertical differentiation in the water permeability of carbonate Triassic rocks in the light of a statistical analysis of the results of pumping test (Silesia – Cracow Monocline). *Kwart. Geol.* 20, 2: 381–399.
- Motyka J., Nieć M., Wilk Z. (1978), O pewnym zastosowaniu metody analizy trendu powierzchni w badaniach hydrogeologicznych. (Certain application of trend surfaces analysis to geohydrology). *Rocz. Pol. Tow. Geol.* 48, 1; 129–144.
- Nguyen-Khac-An (1971), Zagadnienie ciosu na kopalni „Bolesław”. Praca doktorska AGH Kraków.
- Radomski A., Unrug R. (1977), Metodyka pomiaru porowatości i szczelinowatości w skałach węglanowych. (Methodology of measuring porosity and fissurity of carbonate rocks). *Prz. Geol.* 1: 589–594.
- Sass-Gustkiewicz M. (1971), Rudy cynku i ołowiu w kawernach krasowych. (Zinc and Lead Ores in Karst Cavities). *Rudy i Met. Nieżel.* 7: 347–349.
- Streltsova T.D. (1976), Hydrodynamics of Groundwater Flow in a Fractured Formation. *Water Res. Research*, 12, 3: 405–414.
- Śmietański Z. (1969), Metoda analogii hydraulicznych w ocenie procesów niustalonej filtracji, przy odwadnianiu kopalń odkrywkowych. (The Method of Hydraulic Analogies in the Evaluation of Processes of Unsteady Filtration in the Course of Drainage Open-Work Mines). *Pr. geol. PAN*, 56, pp. 78.
- Troskoleński A.T. (1962) Hydromechanika. Wyd. Nauk. Techn. Warszawa, pp. 516.
- Wilk Z., Motyka J., Niewdana J. (1971). Charakterystyka i klasyfikacja przejawów wody w wyrobiskach kopalni pracującej w szczelinowo-krasowym poziomie wodonośnym. (The Characteristics and classification of the discharges of ground-water in mine workings driven in the fissure-karst water-bearing horizon). *Zesz. Nauk. AGH, Geologia*, 14: 43–62.
- Wilk Z., Motyka J., Niewdana J. (1973), Geologiczne i hydrogeologiczne uwarunkowania

- powstania zapadlisk na obszarze górniczym jednej z kopalń rud cynkowo-ołowiowych. (Geological and hydrogeological conditions of the origin of sink holes on a mine field of one of the zinc and lead ore mines). *Biul. Inst. Geol.* 277. Z badań hydrogeolog. w Polsce, 3: 359—378.
- Wilk Z., Motyka J. (1977), Kontakty między poziomami wodonośnymi w olkuskim rejonie kopalnictwa rud. (Contacts between water-bearing horizons (Olkusz ore mining region, near Cracow). *Rocz. Pol. Tow. Geol.*, 47, 1: 115—143.
- Wilk Z., Adamczyk A.F., Biernacki J., Motyka J. (1977), Wykształcenie strefy uskoku Pomorzany i jego hydrogeologiczna charakterystyka. (Geological and hydrogeological characteristics of the Pomorzany fault zone). *Rocz. Pol. Tow. Geol.*, 47, 3: 459—481.
- Wilk Z., Motyka J., Borczak St., Makowski Z. (w druku), Hydrogeologiczne własności przestrzeni porowej utworów wapienia muszlowego i retu w rejonie olkusko-zawierciańskim. (Hydrogeological properties of the pore space of the Muschelkalk and Rhoethian, Olkusz—Zawiercie District). *Ann. Soc. Geol. Poloniae* (in press).
- Wittke W., Louis C. (1968), Modellversuche zur Durchströmung Klüftiger Medien. Felsmechanik und Ingenieurgeologie, Suppl. IV: Aktuelle Probleme der Geomechanik und deren theoretische Anwendung, Springer-Verlag. Wien—New York. pp. 52—70.
- Zoetl J.G. (1974), Karsthydrogeologie. Springer-Verlag. Wien—New York. pp. 291.
- Бабушкин В. Д. и др. (1972), Прогноз водопритоков в горные выработки и водозаборы подземных вод в трещиноватых и закарстованных породах. Издат. „Недра”, Москва, 196 с.
- Баренблатт Г.И., Желтов Ю.П. (1960), Об основных уравнениях фильтрации однородных жидкостей в трещиноватых породах. Докл. АН СССР, 132, 3: 545—548, Москва.
- Бейкер В.Дж. (1956), Течение жидкостей в трещиноватых породах. Матер. 4 Межд. Нефт. Конгр. Т. 3. Бурение скважин и добыча нефти и газа. Гостоптехиздат. Москва, 363—376.
- Боревский Б. В., Хордикайнен М. А., Язвин Л. С. (1976), Разведка и оценка эксплуатационных запасов месторождений подземных вод в трещинно-карстовых пластах. Издат. „Недра”, Москва, 247с.
- Володько И. Ф. (1941), К методике лабораторного изучения движения подземных вод в трещиноватых породах. Гидрогеол. и инж. геол. Сборник статей, 8: 30—38, Москва—Ленинград.
- Гавич И. К. (1966), Некоторые вопросы неустановившейся фильтрации в анизотропных пластах. Труды коорд. совещ. по гидротехнике. 25: 263—275, Москва—Ленинград.
- Жиленков В. Н. (1967), О закономерностях фильтрации воды в трещиноватых скальных породах. Изв. ВНИИГ, 84: 269—276, Ленинград.
- Керкис Е. Е. (1975), Методы изучения фильтрационных свойств горных пород. Издат. „Недра”, Ленингр. отдел., 231 с.
- Ломизе Г. М. (1951), Фильтрация в трещиноватых породах. Издат. Госэнергоиздат, Москва—Ленинград, 127 с.
- Ромм Е. С. (1966), Фильтрационные свойства трещиноватых горных пород. Издат. „Недра” Москва, 283 с.

STRESZCZENIE

Autorzy przeprowadzili swoje badania w kopalniach rud cynku i ołowiu Olkusz i Pomorzany, w utworach wapienia muszlowego, na głębokości około 100 do 150 m. Objęły one pomiary elementów geometrycznych szczelin i spękań (długość, rozwarcie, kierunek) oraz kartowanie i pomiary morfometryczne napotkanych w tych kopalniach form krasowych. Wyniki pomiarów rozwarcia szczelin zestawiono w tabeli 1 i przedstawiono na histogramach (fig. 2, 3). Stwierdzono, że rozkład rozwarcia szczelin jest asymetryczny, prawoskośny. Modalne wartości rozwarcia

szczelin wynosiły około 0,2 mm, największe zaś około 5 mm. Stwierdzono zmniejszenie się liczby najszerszych szczelin z głębokością.

Na podstawie tych pomiarów obliczono wskaźniki szczelinowości powierzchniowej n_F wzorem (1) i powierzchniową gęstość spękań Γ_F wzorem (2). We wzorach tych oznaczają: b_i – rozwarcie poszczególniej szczeliny (m), i – długość poszczególniej szczeliny (m), F – powierzchnię przekroju badanego fragmentu odsłoniętej skały (m²).

Wyniki pomiarów szerokości i długości szczelin posłużyły autorom do obliczenia zastępczego (z punktu widzenia natężenia przepływu wody) rozwarcia szczelin badanego masywu skalnego, b_m . W tym celu założyli równość natężenia przepływu wody przez fragment rzeczywistego masywu pociętego szczelinami o różnej szerokości i przez, o tej samej wielkości, fragment fikcyjnego masywu pociętego szczelinami o identycznym rozwarciu b_m i sumarycznej długości równej łącznej długości szczelin we fragmencie masywu rzeczywistego. Do obliczenia zastępczego rozwarcia szczelin b_m zastosowano równanie Bussinesq'a wraz z upraszczającym założeniem, że spadek hydrauliczny jest identyczny we wszystkich szczelinach. Założenie równości przepływu jest wyrażone równaniem (3), a wielkość rozwarcia zastępczego wzorem (4). We wzorach tych oznaczają: g – przyspieszenie ziemskie (m · s⁻²), J – gradient hydrauliczny, ν – lepkość kinematyczna (m² · s⁻¹).

Kontury przekrojów kawern i kanałów krasowych przeciętych wyrobiskami podziemnymi przenoszono w skali na rysunek, określano wielkość ich powierzchni i mierzono kierunki dostępnych kanałów krasowych. Zwrócono uwagę, że badane powierzchnie są powierzchniami intersekcyjnymi (fig. 1).

Charakterystyczną cechą napotkanych kanałów krasowych są bardzo nierówne ściany (fig. 6, 7), co może wskazywać, iż w ich powstaniu decydujący udział miał proces ługowania. Do rzadkości należą kanały o wygładzonych ścianach, typu rur krasowych, przy powstaniu których niemałe znaczenie miał zapewne także proces mechanicznego poszerzenia kanału przez płynącą wodę. Niektóre kanały są wyraźnie ograniczone z jednej lub dwu stron fugami międzyławicowymi (fig. 6).

Rozpatrywane przekroje kanałów krasowych porównano do elips o takiej samej powierzchni, a jako charakterystykę kształtu danego przekroju przyjęto stosunek poziomej półosi elipsy (x) do półosi pionowej (y). Wielkość jednej półosi, najczęściej dłuższej, mierzono bezpośrednio na ociosie wyrobiska, długość zaś drugiej obliczano ze wzoru (5), w którym F_k oznacza powierzchnię przekroju kanału krasowego. Na podstawie wielkości stosunku x/y wydzielono trzy rodzaje przekrojów: pionowo wydłużone ($x/y < 0,75$), które stanowiły 40% ogółu badanych form, o przekroju regularnym, ($x/y = 0,75 \div 1,25$), których było około 25% i pionowo wydłużone ($x/y > 1,25$), których było około 37%. Zwrócono uwagę na pewne prawidłowości rządzące rozmieszczeniem poszczególnych rodzajów w profilu stratygraficznym. Zauważono słabą zależność między kształtem a wielkością przekrojów kanałów krasowych (fig. 8). Duże przekroje są zazwyczaj poziomo wydłużone, co wskazuje, że kanały te rozwijały się na fugach międzyławicowych.

Najczęstszy kierunek badanych kanałów krasowych (40 do 80°) nie odpowiada kierunkom głównych dyslokacji w rejonie olkuskim (fig. 9).

Wydzielono i krótko omówiono cztery systemy przestrzeni, które tworzą wewnętrzną strukturę hydrauliczną badanego wodonośca, a mianowicie: pory, szczeliny, otwarte kanały krasowe i wypełnione formy krasowe (fig. 10).

Wyróżniono i krótko scharakteryzowano cztery znane z literatury sposoby podejścia do metodyki obliczeń przepływów wody w skałach szczelinowych. W praktyce hydrogeologicznej, zwłaszcza przy obliczeniach w skali regionalnej, najczęściej traktuje się skały szczelinowe tak jak ośrodek porowy. Dlatego autorzy podjęli próbę porównania wartości współczynników filtracji utworów wapienia muszlowego w rejonie olkuskim, uzyskanych na podstawie wyników próbnych pompowań ze współczynnikami oszacowanymi na podstawie bezpośrednich pomiarów elementów geometrycznych szczelin. W tym celu uczynili założenie wyrażone równaniem (6) oraz daleko upraszczające założenie o równości gradientu hydraulicznego w porównywanych ośrodkach: porowym i szczelinowym. W równaniu (6) Q_m oznacza natężenie przepływu wody przez przekrój masywu spękanego, zaś Q_p natężenie przepływu wody przez identyczny co do wielkości przekrój przez ośrodek porowy. Założenie równości spadku hydraulicznego we wszystkich szczelinach ośrodka spękanego byłoby spełnione wówczas, gdyby szczeliny były równoległe do siebie i jednakowo szerokie. Zastępując lewą stronę równości (6) równaniem Bussinesq'a (3) z uwzględnieniem szorstkości, zaś prawą stronę najprostszą postacią prawa Darcy otrzymano równość (7), gdzie B_i oznacza bezwymiarowy parametr uwzględniający szorstkość pojedynczej szczeliny i jej szerokość. Po przyjęciu stałej wartości tego parametru (wg Łomize i Wittke-Luisa – wartość średnia) oraz wartości lepkości kinematycznej wody w temperaturze 10°C otrzymano wzór na oszacowanie przybliżonej wartości współczynnika filtracji ośrodka szczelinowego (8). Wyniki obliczeń dla wybranych fragmentów badanego masywu skalnego zestawiono w tabeli 1. Wartości k oszacowane na takiej drodze są porównywalne z wartościami uzyskanymi na podstawie wyników próbnych pompowań, podanymi przez autorów w pracy z 1976 r.

W ostatnim rozdziale pracy autorzy zajęli się oszacowaniem wielkości współczynnika tarcia hydraulicznego przy przepływie wody przez badane kanały krasowe. Uczynili przy tym szereg daleko upraszczających założeń dotyczących kołowego przekroju badanych kanałów krasowych, prędkości przepływu wody w tych kanałach v , liczby Reynoldsa Re , jej krytycznej wielkości Re_{kr} , i bezwzględnej szorstkości ścian kanałów krasowych w . Określając wartość promienia zastępczego d_z przekrojów badanych kanałów krasowych i korzystając ze znanych z literatury wzorów Misesa i Colebrooka-White'a metodą kolejnych przybliżeń oszacowano wartości λ .

Jak to wynika z tabeli 2, wartości te obliczone obydwoma wzorami różnią się między sobą mniej więcej o jeden rząd wielkości. Przyczyna tego może leżeć m.in. w przyjętych założeniach.

W zakończeniu pracy autorzy zwracają uwagę na praktyczne znaczenie podjętych badań dla podnoszenia wiarygodności prognoz dopływów do wyrobisk górniczych w rejonie olkuskim oraz na pożądane kierunki dalszych badań.